

**a\_g\_i\_**

**POMPE**

## **POMPE SPECIALI PER INDUSTRIA**

special pumps for industrial processes



**Pompe a doppia  
membrana pneumatica**

**ALMATEC**  
Part of Pump Solutions Group  
A **DOVER** COMPANY





E-Series



Chemisor



FUTUR Series



AHD Series



BIOCOR Series

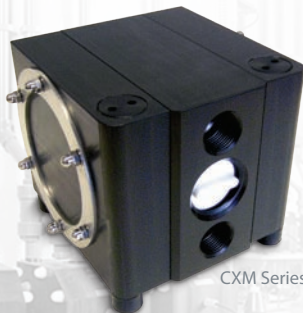

CXM Series

Almatec® Maschinenbau GmbH is a premier manufacturer of air-operated double-diaphragm (AODD) pumps. Headquartered in Kamp-Lintfort, Germany, Almatec is a product brand within PSG®, Oakbrook Terrace, IL, USA, a Dover company. With a reputation for engineering excellence that spans more than three decades, the Almatec name has become synonymous with quality, reliability and safety. This reputation will continue to grow thanks to an affiliation with PSG, making Almatec a global powerhouse within the AODD pump market.

Since it was founded in 1984, Almatec has continued to redefine what a state-of-the-art solid plastic AODD pump looks like by developing new and innovative product characteristics. Every pump that Almatec manufactures is of the highest quality, with unique features that customers have come to rely on, including a solid construction, energy-efficient air control system, industry-leading diaphragms and best-in-class materials of construction. In addition, Almatec is constantly striving to create new product innovations and improvements that have resulted in a wide range of products and the ability to penetrate new markets. By extending its product line, Almatec is able to offer sophisticated technical and economical solutions.

## Safety. Quality. Reliability.

The unique PERSWING P® technology is a precision air control system that features optimal performance. The metal-free, pneumatically pilot-operated PERSWING P® ensures accurate non-stalling operation and is characterized by low noise levels. Only two moving parts ensure minimal maintenance and lube-free operation.

Almatec plastic pumps feature a solid body construction made out of virgin grade PE or PTFE materials that support the necessary weight for a reciprocating pump. The high static mass with required wall thicknesses for each component leads to a smooth operation and eliminates the need for external metal parts. The mechanical machining of a solid plastic block is economical thanks to modern CNC technology, enabling tight tolerances and maximum value.

Almatec also features best-in-class diaphragms providing a smooth profile that is uninterrupted by any seals, maximizing containment and clean-ability. The diaphragms are designed to simplify assembly, reduce air consumption and optimize performance.

# Markets Served



## Process

Almatec's air-operated diaphragm pumps are the pumps the chemical, semiconductor, paint and coatings, and paper and printing industries turn to when they demand safety, quality and reliability for their respective applications. Almatec pumps conform to the ATEX directive, making them suitable for use with flammable liquids and environments with an explosive atmosphere.

### Typical Applications Handled:

- Acids
- Bases
- Solvents
- Sludge
- UV varnishes
- Glues
- Printing inks
- Etching agents
- Emulsions
- High-purity chemicals

## Energy

Almatec is heavily invested in the solar or photovoltaic industry as the world economy increases its focus on renewable energies. The E-Series pump is especially well-suited for use in the manufacture of silicon solar cells (wafers).

### Typical Applications Handled:

- Silicon solar cells
- Slurry
- Chemical treatment of wafers
- Hard, sharp silicon particle by-products from wafer cutting process
- Highly abrasive media

## Hygienic

Almatec's pumps meet the highest standards for processes in the biopharmaceutical industry as well as in the food and beverage industry, complying with EHEDG, EC1935, FDA and USP Class VI standards (depending on the pump series). Almatec pumps have high surface quality, the ability to trace the materials used and CIP/SIP capabilities.

### Typical Applications Handled:

- Active pharmaceutical ingredients
- Biotechnical ingredients
- Cosmetics
- Live cultures
- Food ingredients
- Fruit juices, sauces, pastries
- Concentrates, aromas

## Water/Wastewater

In industrial water treatment applications, Almatec's air-operated diaphragm pumps are used for taking samples for analysis around the clock, wastewater neutralization and feeding filter presses with sludge. Almatec pumps allow operation over the entire range of flow rates without a risk of overpressure and without any additional regulation.

### Typical Applications Handled:

- Chemical handling
- Transfer
- Ion exchange
- Sludge
- Neutralization

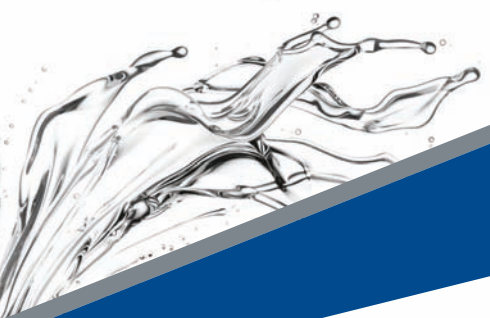

## Applications

The fields of application include chemical industry, pharmaceuticals, cosmetics, food and beverage, ceramics, surface treatment, emergency services, power plants, refineries, mechanical engineering, textile industry, water processing, waste disposal, paper industry, electronics, solar industry.

Compatible liquids include sludges, acids, alkalis, solvents, slurries, emulsions, mixtures of liquids and solids, resins, powders, aqueous solutions.

These liquids may be of high or low viscosity, abrasive, thixotropic, hazardous, toxic, non-lubricating, hot, cold, coagulating, shear sensitive, pasty, solids containing, corrosive.

### Chemical Industry

The chemical industry (including the pharmaceuticals industry) is one of the classic areas of application for ALMATEC air-operated diaphragm pumps. Their outstanding characteristics (safety, quality, reliability, solid construction, self-priming and dry-operation capabilities, etc.) play a large role in the transportation of media that often exhibit corrosive, hazardous, toxic, or explosive properties – like acids, bases, solvents, and chemical mixtures. The plastic pumps of the E-SERIES with the PE (abrasion-resistant) and PTFE (almost universally chemically resistant) material options, as well as their conductive versions for ATEX applications, cover an essential part of the chemical industry's pump needs.



**E-SERIES, CHEMICOR, BIORCOR**

### Solar Industry

The value of the solar or photovoltaic industry in the world economy is increasing rapidly due to the growing importance of renewable energies. The Almatec E-SERIES air-operated diaphragm pumps, which do not use any metal on their exterior, are considered to be especially well suited for use in the manufacture of silicon solar cells (wafers) in particular. Possible areas of application in this industry include using pumps made of abrasion-resistant polyethylene for the pumping of slurry before and after the silicon sawing process, as well as chemical treatment of the wafers (using pumps made of PTFE).



**E-SERIES**

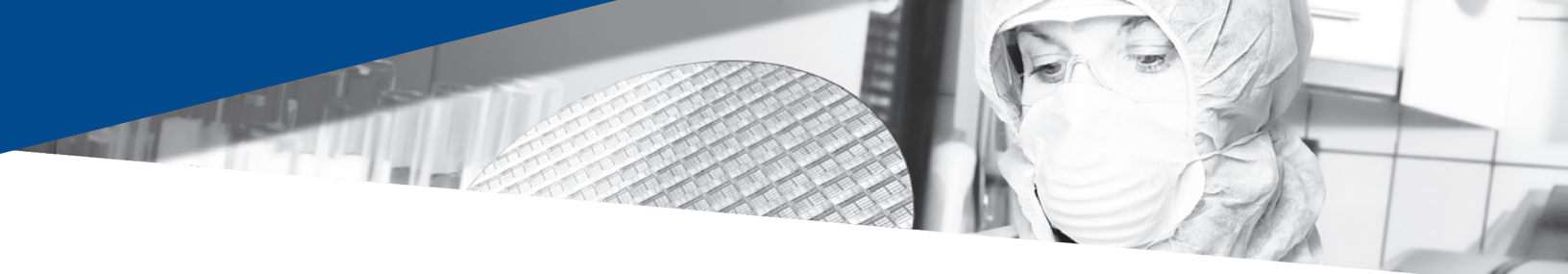

## Semiconductor Industry

The production of semiconductors places especially high demands on a pump. In addition to the special challenges posed by the fairly high temperatures sometimes encountered, particularly for plastics, terms like purity and safety gain a whole new meaning. The completely metal-free Almatec FUTUR pump series is an essential requirement in this case. The supply of high-purity chemicals and their circulation and filtration, as well as the pumping of abrasive slurries and solvents are typical areas of application in the semiconductor industry. Examples of high-purity chemicals that Almatec pumps can successfully handle include  $H_2SO_4$ ,  $HCl$ ,  $HNO_3$ ,  $H_3PO_4$ ,  $HF$  and  $H_2O_2$ , including mixtures of these.

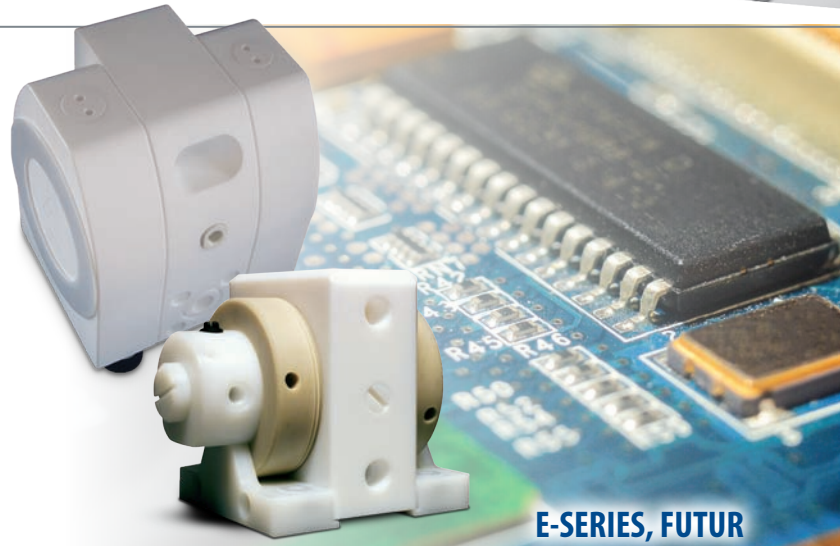

**E-SERIES, FUTUR**

## Ceramic Industry

In the ceramic industry, pumps are needed to transport sludge and glazes, among other uses. An important criterion in the selection of a suitable pump in this case is the abrasion-resistance of the pump materials. A recommended material in the solidly constructed Almatec E-SERIES AODD pump is polyethylene. Studies conducted when utilizing the sand slurry method have confirmed that PE has an abrasion resistance that is seven times higher than that of polypropylene PP — which is often used as a material in pumps — and 1.6 times higher than that of steel. PE also has higher wear-resistance than cast iron or aluminum, for example.



**E-SERIES**

## Biopharmaceutical Industry

Sterile processes are the main focus in the biopharmaceutical industry. Examples of products handled in these applications include active pharmaceutical and biotechnical ingredients, cosmetics, and live cultures. The pumps used in such sterile applications must meet corresponding hygienic standards (EHEDG, EC1935, FDA, USP Class VI) and require SIP and CIP capabilities. The Almatec BIOCOR AODD pump line with their high surface quality and the ability to trace the materials used meet these required criteria.



**BIOCOR**

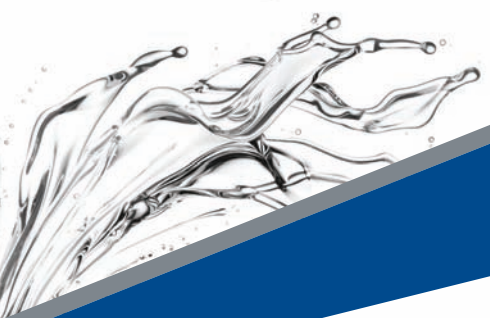

## Applications

### Paint and Varnish Industry

To pump paint and varnish, a pump generally needs to conform to the ATEX directive. The ATEX versions of the Almatec CHEMICOR line of metal pumps meet these requirements. For UV varnishes, there are E-SERIES pumps made of conductive plastic available. Due to the high pressures encountered, Almatec high pressure diaphragm pumps made of stainless steel (AH-S) are used in painting systems where there is only one pump as a central supply. The time required to clean the pump when changing colors is just as low as the amount of cleaning agent needed for cleaning.



**E-SERIES, CHEMICOR, AH-S, CXM**

### Surface Technology Industry

The process chemicals used in surface technology place high requirements on materials and technologies used in the equipment operated in this industry. The media transported range from highly concentrated acids and bases to abrasive slurries. Air-operated double diaphragm pumps from the Almatec E-SERIES line are used in this case to pump etching agents as well as in grinding and drilling emulsions. Sludge can be compacted for disposal purposes using AHD/AHS Series high-pressure pumps in a filter press.



**E-SERIES, AHD/AHS**



## Paper Industry

In the paper and printing industries, air-operated double-diaphragm (AODD) pumps are primarily used to transport glues and printing inks. In many cases, a glue application pump of average size and made of PE from the E-SERIES is used. In the case of printing inks, Almatec pumps with a draining system offer numerous advantages. The colors must not be allowed to mix during a color change. The draining system allows the pump and pipeline to be emptied without disassembly. The color flows back into the supply container (saving money), and the amount of cleaning agent and solvent required is significantly reduced, thereby reducing the impact on the environment.



**E-SERIES, CHEMICOR**

## Water Treatment Industry

In industrial water-treatment applications, the Almatec air-operated diaphragm pumps are used for the following tasks, among others: taking samples for analysis around the clock, wastewater neutralization and feeding filter presses with sludge. While sample-taking and the proportioning of neutralization chemicals are done primarily using E-SERIES, CHEMICOR and CXM pumps, the Almatec high pressure pumps of the AHD series are available for filter-press feeding. These pumps allow operation over the entire range of flow rates without a risk of overpressure and without any additional regulation due to their ability to automatically adjust the pressure/quantity.



**E-SERIES, CHEMICOR, AHD, CXM**





TECHNOLOGY: DIAPHRAGM

## E-Series AODD Pumps

The E-Series plastic air-operated double diaphragm (AODD) pump is made of PE, PTFE, PE conductive and PTFE conductive. The conductive models meet the ATEX requirement of the 94/9/EG directive. E-Series pumps are very well suited for use with hazardous chemicals such as acids, caustics and solvents.

### Applications

- Abrasive Slurries
- Solar Cell
- Biopharmaceutical
- Chemicals
- Etching Agents
- Ceramic
- Sludge Transfer
- Glazes Transfer
- Paints
- Varnish
- High Concentrated Acids and Bases
- Grinding and Drilling Emulsions
- Paper and Printing
- Glue Transport
- Printing Inks Transport
- Industrial Water Treatment
- Sample Analysis
- Wastewater Neutralization
- Feeding Filter Presses with Sludge
- Chemical Treatment of Wafers
- Corrosive, Hazardous or Toxic Chemicals

### Features and Benefits:

- Machined plastic design
- Increased capacity
- Increased safety
- Decreased air consumption
- Easy cleanability
- Reduced noise level
- Decreased downtime
- Optimized flow pattern
- Increased quality
- Long service life
- Increased reliability
- Used in demanding process applications
- Robust plastic design with reinforcement ring for enhanced sealing and torque retention
- Maintenance-free air distribution system (ADS) PERSWING P<sup>®</sup>
- Integrated pulsation dampener available—threaded or flanged versions

### Technical Data:

- Polyethylene (PE) and PTFE models with conductive versions available
- Seven sizes: 6mm (1/4 in.) to 76mm (3 in.)
- NPT liquid outlet, DIN or ANSI flange connections
- Max. temperature: 120°C (248°F)
- Ball or cylinder check valves—interchangeable configuration

### Performance Data:

- Max. flow: 800 L/min (210 gpm)
- Max. suction lift: 5m (16.4 ft) dry, 9.5m (31.2 ft) wet
- Max. solids size: 15mm (9/16 in.)

### Certifications & Associations:



E-Series  
AODD Pump

## Inside the E-Series

The housing parts are tightened to each other via housing bolts. Instead of single bolts pressing punctually against the housing, all housing bolts are tightened against a diaphragm-sized containment ring on each side. This structure results in a more even spreading of the housing bolt force and increased permissible bolt torque.

The flow resistance is reduced via an optimized flow pattern to increase the efficiency factor of the pump. Compared to its predecessor, the A Series, the same air flow achieves a high fluid flow, while less air flow is required from the same fluid flow.

## Machined for Precision

Almatec's solid plastic block increases the pump's strength and life cycle while eliminating many maintenance concerns. The E-Series' CNC machined solid block of PTFE or PE allows Almatec to deal with the harshest environments. The E-Series solid plastic block construction is mechanically machined rather than injection molded, as is the case with many of its competitors. The CNC technology enables tight tolerances, along with reduced vibration, less risk of leakage, and greater stability and durability. The high static mass leads to smooth operation with reduced vibration.

### Materials

For the E-Series pumps, the following materials are available:

- **Housing:** PE, PE conductive, PTFE, and PTFE conductive
- **Diaphragms:** EPDM, PTFE/EPDM, NBR
- **Ball valves:** EPDM, PTFE, NBR, stainless steel
- **Cylinder valves:** PTFE

### Sizes

The E-Series is available in seven pump sizes to achieve the maximum capacities:

- **E08:** 0.9 m<sup>3</sup>/h, 15 L/min, 4 gpm
- **E10:** 1.4 m<sup>3</sup>/h, 23 L/min, 6 gpm
- **E15:** 3.4 m<sup>3</sup>/h, 55 L/min, 15 gpm
- **E25:** 8 m<sup>3</sup>/h, 130 L/min, 35 gpm
- **E40:** 20 m<sup>3</sup>/h, 330 L/min, 88 gpm
- **E50:** 36 m<sup>3</sup>/h, 600 L/min, 160 gpm
- **E80:** 48 m<sup>3</sup>/h, 800 L/min, 210 gpm

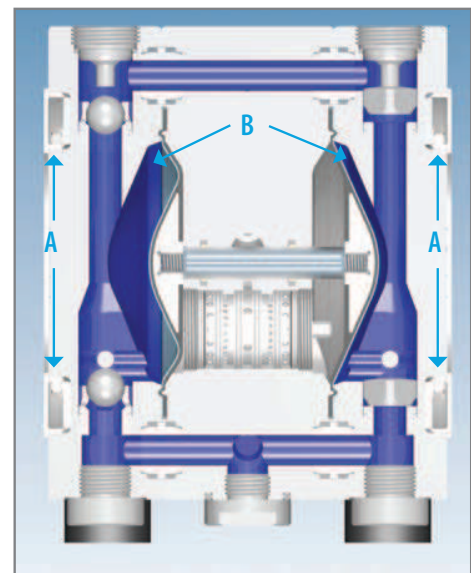
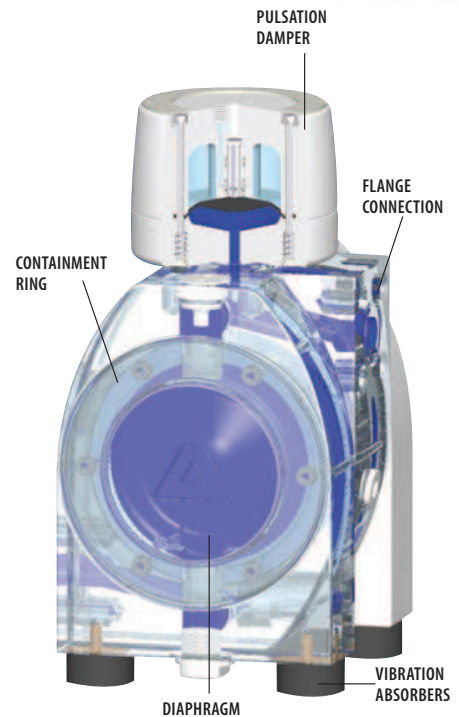

AODD pumps offer superior containment due to the fact that they don't use mechanical seals and packing. In the Almatec pump illustration shown above, the stainless steel Containment Ring (A) clamps tightly on two sides of the pump housing, pulling it together over the smooth, integrated metal core diaphragm (B), which further increases safety and ensures a tight seal.

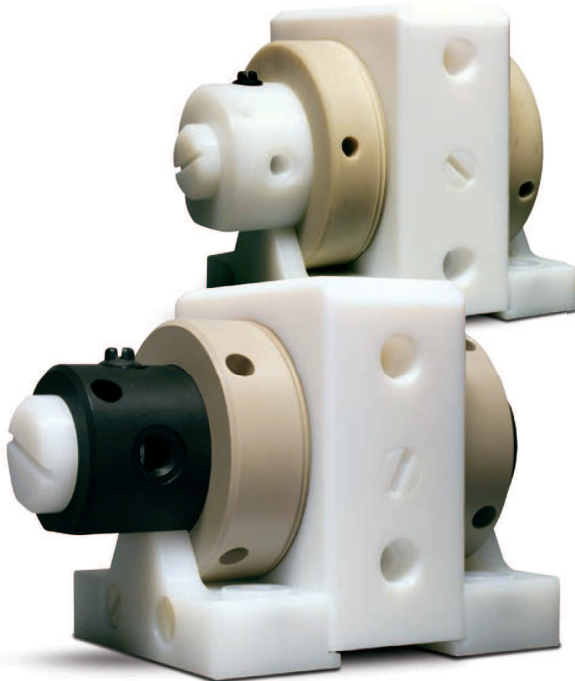
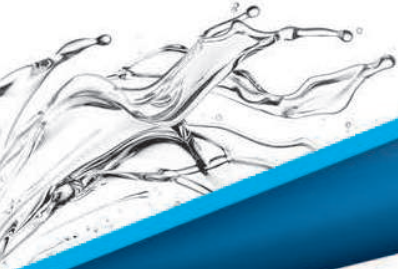

FUTUR Series  
AODD Pump

TECHNOLOGY: DIAPHRAGM

## FUTUR Series AODD Pumps

Since 1991, Almatec has manufactured FUTUR pneumatic diaphragm pumps, which are designed specifically for chemical supply and circulation in the semiconductor industry. The liquids handled in the semiconductor industry have different demands, requiring a unique pump to meet those demands.

### Applications

- Semiconductor
- High-temperature applications
- High-purity chemicals

### Features and Benefits:

- Designed especially for the semiconductor industry
- 100% metal free plastic pumps
- No O-ring sealing in wetted areas
- Flow-through design
- No metal fixing elements, such as tie rods or clamps
- Integrated pulsation dampener available
- Assembled in Class 100 Cleanroom
- Low noise levels
- Easy to assemble and disassemble
- Compact
- No metal fixing elements, such as tie rods or clamp

### Technical Data:

- Machined plastic design, polyethylene (PE) and PTFE
- Optimized PTFE diaphragm technology
- Five sizes: 10mm (3/8 in.) to 38mm (1-1/2 in.)
- NPT ports
- Max. temperature: 200° C (390° F)
- Accurate fluid transfer

### Performance Data:

- Max. flow: 200 L/min (52 gpm)
- Max. suction lift: 4m (13.1 ft) dry, 9m (29.5 ft) wet

### Certifications & Associations:





## Inside the FUTUR Series

In order to meet the strict demands of the semiconductor industry, the FUTUR Series is available in four materials:

- Four sizes made of PTFE/UPPE for acids and caustics up to 130°C/266°F (FUTUR T Model)
- Two sizes made of PTFE for hot applications with acids and caustics up to 200°C/390°F (FUTUR H Model)
- Four sizes made of UPPE for slurries (FUTUR E Model)
- Two sizes made of stainless steel for solvents (FUTUR SLS Model)



The pump sizes achieve maximum capacities between 10 and 200 L/min (2.5 to 52 gpm).

For every pump size and material, an appropriate pulsation dampener is available.

All FUTUR pumps are self-priming pneumatic diaphragm pumps which can run dry.

They have a compact, simple design with few parts only. The housing parts are machined from solid blocks. FUTUR pumps are cleaned, assembled and tested in a Class 100 cleanroom line.

### The latest generation of FUTUR pumps is the FUTUR-Omega Series:

- Entirely made of PTFE
- New construction with  $\Omega$ -shaped base frame
- Diaphragm and center housing with rotation prevention
- New PTFE material for the diaphragms
- Three sizes with maximum capacities of 20, 50 and 100 L/min (5.3, 13 and 26 gpm)
- Depending on the application, also available made entirely of polyethylene and stainless steel

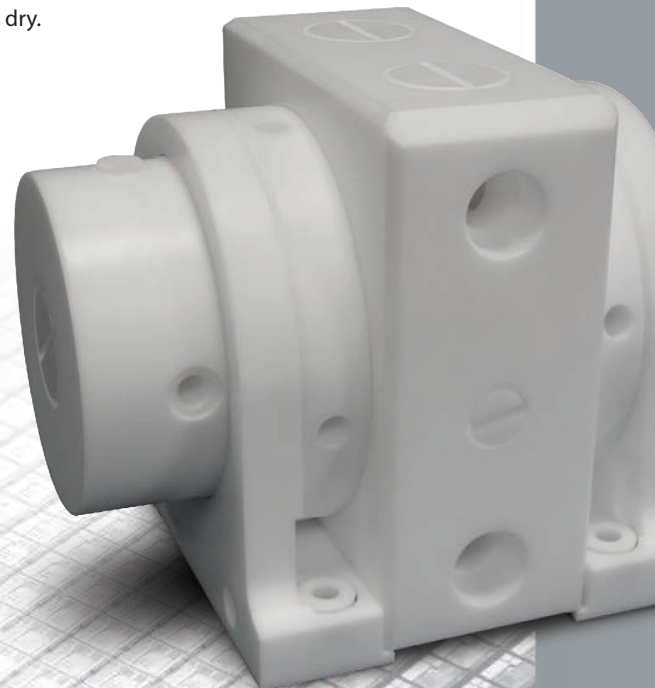



BIOCOR Series  
AODD Pump

TECHNOLOGY: DIAPHRAGM

## BIOCOR Series AODD Pumps

BIOCOR pumps are specially designed for sterile applications within the pharmaceutical, biotechnical and food industry. The air-operated double diaphragm pumps are built in compliance with the corresponding hygienics standards (EHEDG, 3A, FDA, USP Class VI). The pump's special design with an integrated cleaning system enables CIP and SIP capability.

### Applications

- Chemicals
- Cosmetics
- Perishable products requiring cleanability
- Live cultures
- Active pharmaceutical and biotechnical ingredients

### Features and Benefits:

- Designed for high-end sanitary / hygienic applications
- Sterile design for maximum cleanability
- Can be drained without disassembly
- Designed for superior product containment
- Clean in Place (CIP) and Sterilize in Place (SIP) capabilities
- Improved safety
- Increased reliability
- High surface quality
- High traceability

### Technical Data:

- Wetted components: 316L (Based Standard II) center housing polyethylene conductive
- Surface finish: Ra 0.4  $\mu\text{m}$  (15  $\mu\text{-in.}$ )
- Three sizes: 25mm (1 in.) to 51 mm (2 in.)
- Liquid connections compatible with different sanitary threads
- Valve balls with metal cores

### Performance Data:

- Max. flow: 280 L/min (73 gpm)
- Max. suction lift: 3m (9.8 ft) dry, 9m (29.5 ft) wet
- Max. solids size: 9mm (3/8 in.)

### Certifications & Associations:



## Inside the BIOCOR Series

The AODD pumps are EHEDG certified and conform to the ATEX 94/9/EG directive. There aren't any horizontal areas in the housing parts – an important demand for sterile applications. The pump sizes B20 and B32 come with four ball lifting magnets, which can be attached to the pump housing from the outside at the location of the four ball valves. The ball valves rise up magnetically out of their seats and the pump is drained entirely without having to be dismantled therefore, there are no mechanical ball lifters with parts and seals in the wetted areas.

The BIOCOR series is available in three pump sizes B20, B32 and B40. The material for the wetted housing parts is electropolished SS 316 L (Basel Standard II, ferrite content < 1%) with a surface roughness of  $\leq 0.4 \mu\text{m}$ . The center block is made of polyethylene conductive and the suction and discharge ports are suitable for Tri-clamp or different sanitary threads (Naue, Neumo, DIN 11851, DIN 11864). Diaphragms, ball valves and O-rings are made of PTFE or EPDM (FDA); other materials on request.

### Pump Models:

**B20:** Max capacities of 3.5 m<sup>3</sup>/h (15.4 gpm)

**B32:** Max capacities of 7.5 m<sup>3</sup>/h (33 gpm)

**B40:** Max capacities of 17 m<sup>3</sup>/h (75 gpm)

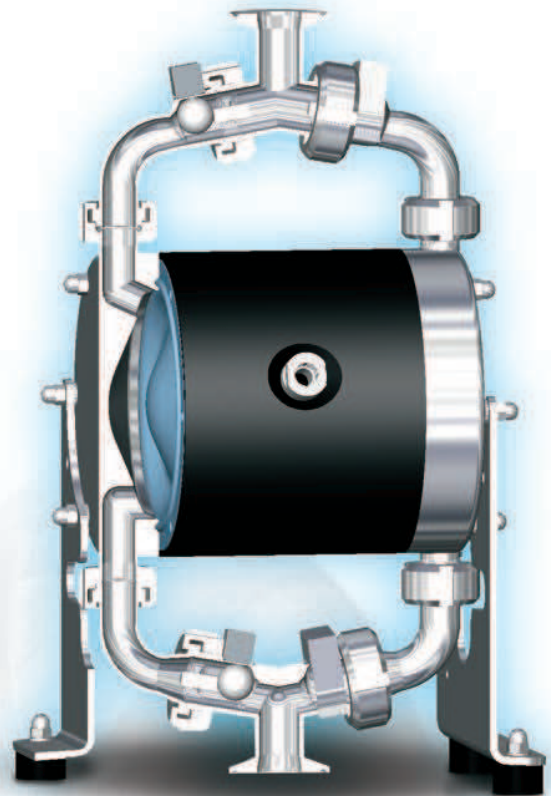



CHEMICOR Series  
AODD Pump

TECHNOLOGY: DIAPHRAGM

## CHEMICOR Series AODD Pumps

The metal pneumatic diaphragm pumps feature soft contours, smooth flow channels and no dead spaces. CHEMICOR pumps contain a center block made of nylon or PE conductive material which meets the ATEX requirements of the 94/9/EG directive.

### Applications

- Chemicals
- Industrial water treatment
- Corrosive, hazardous or toxic chemicals
- Sample analysis
- Paints
- Wastewater neutralization
- Varnish
- Paper and printing
- Glue transport
- Printing inks transport
- Food Processing

### Features and Benefits:

- Designed for heavy-duty process applications
- Soft contours, smooth flow channels, no dead spaces
- Rotating inlet and discharge parts
- Available in multiple surface finishes
- Insensitive to solids
- Decreased downtime
- Easy start-up
- Improved safety
- Increased reliability
- Easy cleanability

### Technical Data:

- Stainless steel precision castings
- Non-wetted center section – Nylon or conductive polyethylene (PE)
- Three sizes: 19mm (3/4 in.) to 51mm (2 in.)
- BSP or NPT liquid outlet connections
- Max. temperature: 130°C (266°F)
- Valve balls for handling solids

### Performance Data:

- Max. flow: 400 L/min (105 gpm)
- Max. suction lift: 3m (9.8 ft) dry, 9m (29.5 ft) wet
- Max. solids size: 14mm (9/16 in.)

### Certifications & Associations:





TECHNOLOGY: DIAPHRAGM

## AH Series AODD Pumps

High-pressure plastic diaphragm pumps are designed for charging filter presses with chemical wastes and special sludge. All housing parts in contact with the product are made of PE UHMW, which is seven times more resistant to abrasion than PP, and is more resistant to wear than aluminum, iron or steel. The self-priming pump does not possess any drives, rotating parts or shaft seals.

### Applications

- Feeding filter presses with sludge
- High-pressure chemical feed
- Grinding and drilling emulsions
- Pressure boost
- Paints
- Coating facilities

### Features and Benefits:

- Eliminates risk of overpressure
- Running dry capability
- Self-priming
- Automatically adjusts pressure/quantity
- Decreased downtime

### Technical Data:

- Wetted housing parts in solid design made of polyethylene
- Non-wetted center section made of Nylon
- Max. temperature: 70°C (158°F)
- Interchangeable ball valves and valve stops
- Heavy duty diaphragms for long service life
- 3 sizes with discharge pressure up to 15 bar (218 psig)

### Performance Data:

- Max. flow: 330 L/min (87 gpm)
- Max. suction lift: 3.5m (11.5 ft) dry, 9.5m (31.2ft)
- Max. solids size: 8mm (0.3 in.)

### Certifications & Associations:



AH Series  
AODD Pump

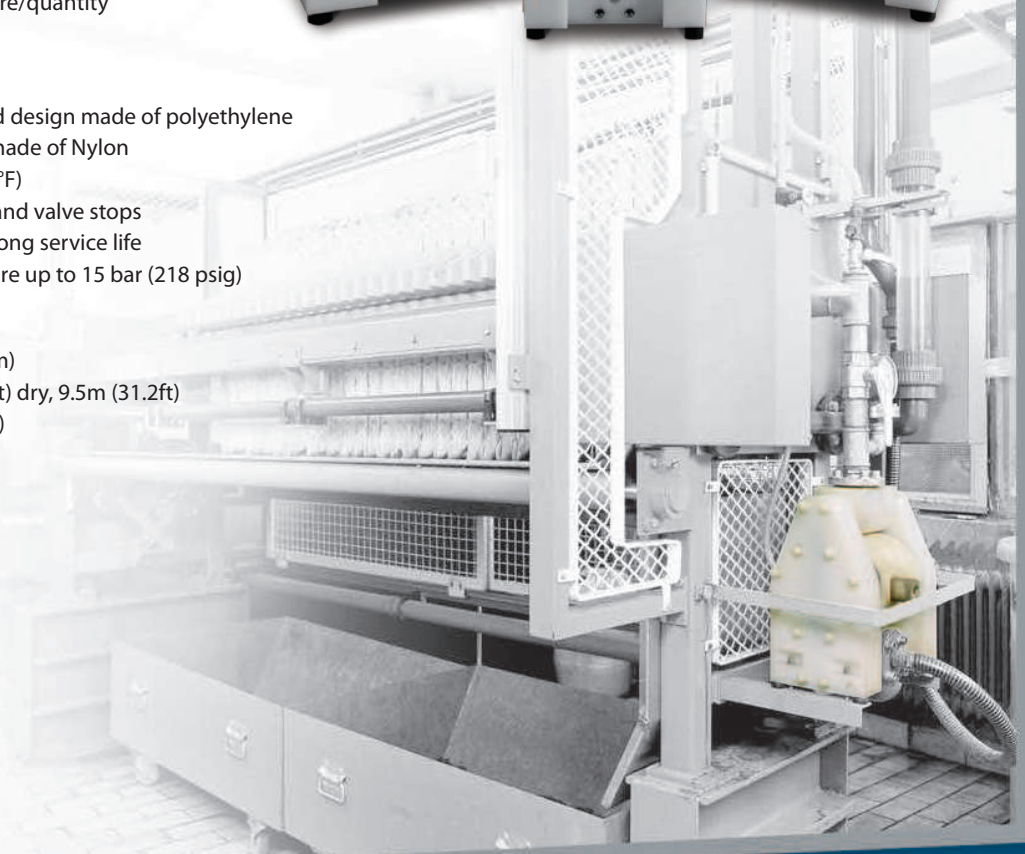



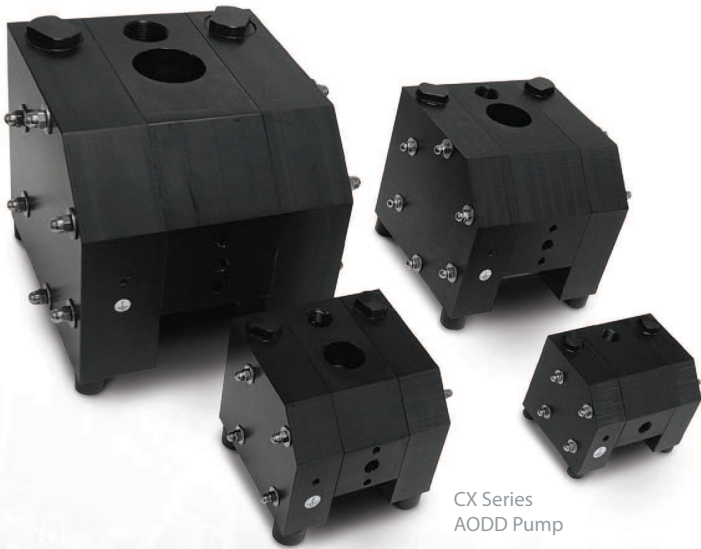
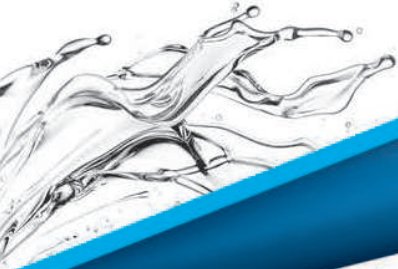

CX Series  
AODD Pump

TECHNOLOGY: DIAPHRAGM

## CX Series AODD Pumps

CX Series pneumatic diaphragm pumps are general-purpose pumps designed for low-to medium-duty applications. Self-priming and protected against dry running, the pumps are used to empty containers down to the very last drop, allowing them to be used for complete and unattended transfer of liquids from one container to another.

### Applications

- Used to empty containers
- Neutralization
- Glue transport
- Cleaning agents

### Features & Benefits

- Self-priming
- Can be infinitely controlled
- Protected against dry running
- Easy to start
- Easily maintained

### Technical Data

- Housings made of solid PE conductive for use in explosion-protected areas
- Composite diaphragms with integrated metal discs
- Max. temperature: 70°C (158°F)
- Ball or cylinder valves

### Performance Data

- Max. flow: 130 L/min (34 gpm)
- Max. suction lift: 4m (13.1 ft) dry, 9m (29.5 ft) wet
- Max. solids size: 4mm (0.16 in.)

### Certifications & Associations:





## Options



### Barrier Chamber System

With the barrier chamber system, the individual diaphragm is replaced by two diaphragms arranged in tandem with a barrier chamber of conductive PE between them and filled with non-conductive liquid. A change in conductivity of the barrier liquid is detected by sensors and signaled to a controller, which triggers an alarm or disconnects the pump, meeting high safety requirements.

### Diaphragm Monitoring

A capacitive sensor installed in the pump muffler detects the presence of all liquids. If the diaphragm ruptures, it outputs a corresponding signal to a controller which triggers an alarm or disconnects the pump via a connected solenoid valve.



### Pulsation Dampers

Pulsation dampers are available if a virtually uniform flow is needed. The E-Series pumps can be equipped with screwed-on or flanged pulsations dampers, while the CHEMICOR and BIOCOR pump series are available with an inline pulsation damper.

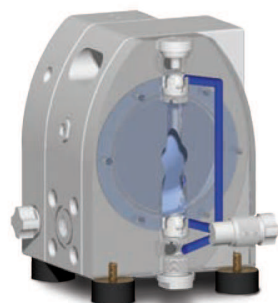

### Draining System

The E-Series pumps, available in sizes 15 to 50, are available with Almatec's special draining system. This unit consists of a by-pass system in the side housings that can be activated easily either via hand-operated valves or pneumatically. The pump and piping can then be drained without having to be dismantled. The amount of cleaning agent and solvent required when changing products is reduced considerably, greatly reducing environmental pollution. For the metal series CHEMICOR pumps, offer another solution. Ball lifters, which are turnable by hand, are fitted to the four ball valves. By turning the handles the ball valves are lifted out of their seats.

### Transport Carts

Many industrial applications not only need stationary air-operated double diaphragm pumps, but mobile pumping units as well. This includes pumps that are designed for use as emergency pump, as short-dated replacement for a pump to be repaired or for decanting between two containers. For these purposes a transport cart is available.



### Stroke Counting

Almatec air-operated double diaphragm pumps can be used continuously or intermittently for hours, minutes or for an exact defined number of strokes. A sensor can be installed in the pump's center housing to accurately count the strokes. This is available in a pneumatic version as well.

### Flange Connection

All E-Series pump sizes—from E 15 to E 80 – can be equipped with thread bushings and flange O-rings for flange connections to DIN or ANSI / PN 10. For the AH Series, a flange connection to DIN or ANSI/PN 16 is standard.



# **Teknofluor srl**

**divisione A.G.I. POMPE**

**Via Pietrasanta 12 - Pal. 5/14**

**20141 Milano - Italia**

**Telefono: (+39) 02 5830 4949**

**e-mail: [info@agipompe.com](mailto:info@agipompe.com)**

**[WWW.AGIPOMPE.COM](http://WWW.AGIPOMPE.COM)**